



Fuso de Esferas / Mancal

Av. Corifeu de Azevedo Marques, 4259/4279
Butantã, São Paulo – SP – CEP 05339-002

Tel/Fax.: (55 11) 5566-0266
www.sferatech.com.br





Codificação do Produto

F5U - 25 05 - T4 - R - 1200 - C7

Classe de Precisão
Comprimento Total (mm)
Direção da Rosca R: Direita L: Esquerda
Quantidade de Circuitos T: 1 Circuito A: 1.8 Circuito
Passo (mm)
Diâmetro (mm)
Tipo de Castanha FSU: DIN 69051 FSC: DIN 69051 Compacta FSE: JIS B 1192 Alta Velocidade

Exemplo de Codificação:

- 1 - Fuso de Esferas**
FSU-2505-T4-R-1200-C7
- 2 - Eixo**
R-2505-R-1200-C7
- 3 - Castanha**
FSU-2505-T4-R

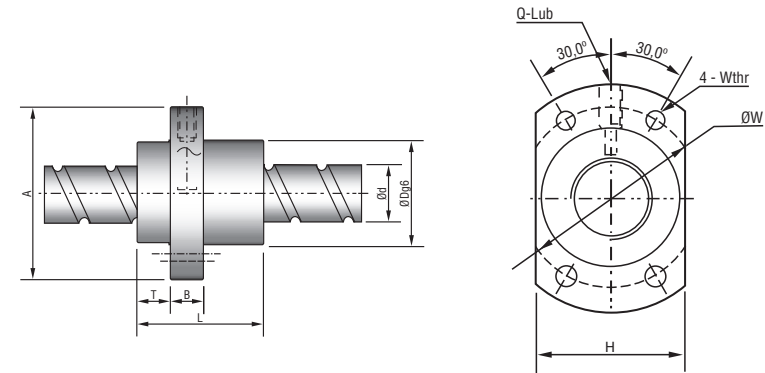

Modelo: FSE (JIS B 1192) Alta Velocidade

Modelo N°	Dimensão														
	d	l	Da	D	A	B	T	L	W	X	H	Q	Ca(kgf)	Coa(kgf)	n
1616	16	16	3.175	32	53	10	10.5	48	42	4.5	38	M6	700	1400	1.8X2
2020	20	20	3.175	39	62	10	10.8	55	50	5.5	46	M6	1100	2500	1.8X2
2525	25	25	3.969	47	74	12	11.2	67	60	6.6	56	M6	1650	3900	1.8X2
3232	32	32	4.762	58	92	15	14	82	74	9	68	M6	2360	5940	1.8X2
4040	40	40	6.350	73	114	17	17	100	93	11	84	M6	3860	9900	1.8X2

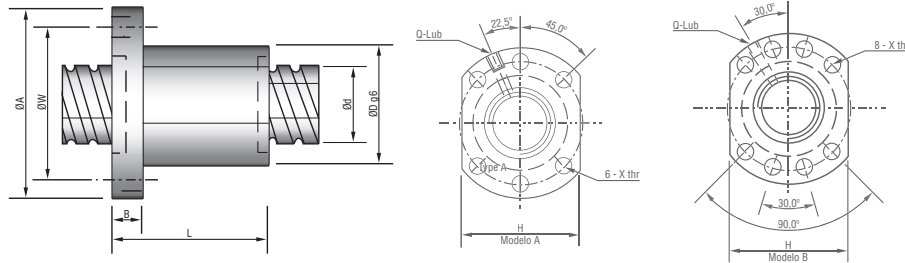

Modelo: FSU (DIN 69051)

Modelo N°	Dimensão														
	d	l	Da	D	A	B	L	W	X	Tipo	H	Q	n	Ca(kgf)	Coa(kgf)
1605 - 4	16	5	3.175	28	48	10	50	38	5.5	A	40	M6	4	980	1650
2005 - 4	20	5	3.175	36	58	10	53	47	6.6	A	44	M6	4	1100	2280
2504 - 4	25	4	2.381	40	62	11	46	51	6.6	A	48	M6	4	666	1920
2505 - 4	25	5	3.175	40	62	10	53	51	6.6	A	48	M6	4	1250	3070
2510 - 4	25	10	4.762	40	62	12	85	51	6.6	A	48	M6	4	2070	4270
3205 - 4	32	5	3.175	50	80	12	53	65	9	A	62	M6	4	1400	4080
3210 - 4	32	10	6.35	50	80	16	90	65	9	A	62	M6	4	3340	7080
4005 - 4	40	5	3.175	63	93	16	56	78	9	B	70	M8	4	1575	5290
4006 - 4	40	6	3.969	63	93	14	60	78	9	B	70	M6	4	2130	6410
4010 - 4	40	10	6.35	63	93	18	93	78	9	B	70	M8	4	3850	9470
5010 - 4	50	10	6.35	75	110	18	93	93	11	B	85	M8	4	4390	12400

Modelo: FSC (DIN 69051) Compacta

Modelo N°	Dimensão														
	d	l	Da	D	A	B	L	W	X	Tipo	H	Q	n	Ca(kgf)	Coa(kgf)
1610-3	16	10	3.175	28	48	12	43	38	5.5	A	40	M6	3	669	1128
4020-3	40	20	5.556	63	93	15	83	78	9	B	70	M8	3	2537	6204



Tabela de Componentes	
Número	Componentes
1	Alojamento
2	Rolamento
3	Trava de Fixação
4	Anel
5	Vedação
6	Porca Quadrada
7	Trava da Porca
8	Anel de Retenção

Guia para utilização de Mancais

Fuso de Esferas Ø	Carga Axial Permissível (kgf)	Carga Estática (kgf)	Rotação Máxima (RPM)	Rolamento	Aplicação	
					Mancal Fixo	Mancal Apoiado
Ø14 - Ø18	217	610	22000	7001A	BK12 FK12	BF12 FF12
Ø20	240	700	19000	7002A	BK15 FK15	BF15 FF15
Ø25 - Ø28	413	1220	16000	7203A	BK17 FK17	BF17 FF17
	428	1340	15000	7004A	BK20	BF20
	587	1690	13000	7204A	FK20	FF20
Ø30 - Ø 36	709	2090	12000	7205A	BK25 FK25	BF25 FF25
Ø40	939	3000	10000	7206A	BK30 FK30	BF30 FF30
Ø45	1466	3750	6000	7207B	BK35	BF35
Ø50	1834	4700	5300	7208B	BK40	BF40

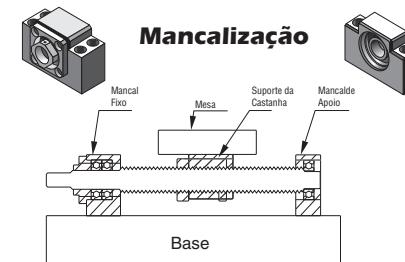
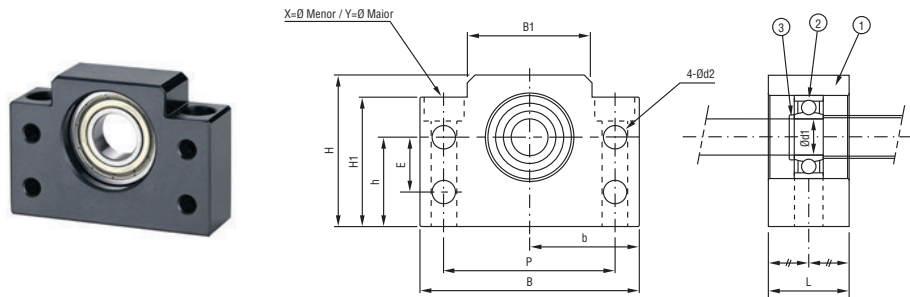

Modelo BF

Modelo	d1	L	B	H	b ± 0.02	h ± 0.02	B1	H1	E	P	d2	X	Y	Z	Rolamento	Anel Elástico	Peso Kgs
BF12	10	20	60	43	30	25	34	32.5	18	46	5.5	6.6	10.8	1.5	6000ZZ	S10	0.35
BF15	15	20	70	48	35	28	40	38	18	54	5.5	6.6	11	6.5	6002ZZ	S15	0.4
BF17	17	23	86	64	43	39	50	55	28	68	6.6	9	14	8.5	6203ZZ	S17	0.75
BF20	20	26	88	60	44	34	52	50	22	70	6.6	9	14	8.5	6004ZZ	S20	0.77
BF25	25	30	106	80	53	48	64	70	33	85	9	11	17	11	6205ZZ	S25	1.45
BF30	30	32	128	89	64	51	76	78	33	102	11	14	20	13	6206ZZ	S30	1.95
BF35	35	32	140	96	70	52	88	79	35	114	11	14	20	13	6207ZZ	S35	2.25
BF40	40	37	160	110	80	60	100	90	37	130	14	18	26	17.5	6208ZZ	S40	3.3

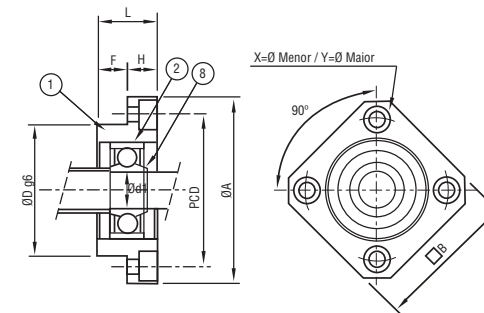

Modelo FF

Modelo	d1	L	H	F	Dg6	A	PCD	B	X	Y	Z	Rolamento	Anel Elástico	Peso Kgs
FF12	10	15	7	8	34	52	42	42	4.5	8	4	6000 ZZ	S10	0.15
FF15	15	17	9	8	40	63	50	52	5.5	9.5	5.5	6002 ZZ	S15	0.22
FF17	17	20	11	9	50	77	62	61	6.6	11	6.5	6203 ZZ	S17	0.35
FF20	20	20	11	9	57	85	70	68	6.6	11	6.5	6204 ZZ	S20	0.45
FF25	25	24	14	10	63	98	80	79	9	14	8.5	6205 ZZ	S25	0.66
FF30	30	27	18	9	75	117	95	93	11	17	11	6206 ZZ	S30	1.05

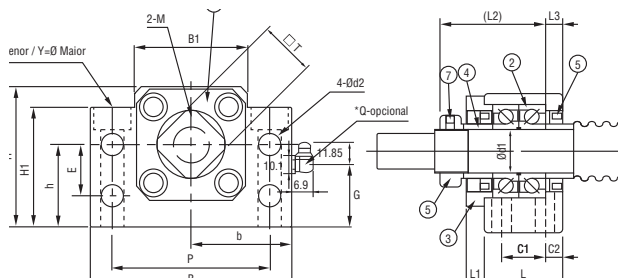

Modelo BK

Modelo	d1	L	L1	L2	L3	B	H	b ± 0.02	h ± 0.02	B1	H1	E	P	C1	C2	d2	X	Y	Z	M	T	G	Q	Peso Kgs
BK12	12	25	5	29.5	5	60	43	30	25	34	32.5	18	46	13	6	5.5	6.6	10.8	1.5	M4	19	18	M6	0.45
BK15	15	27	6	32	6	70	48	35	28	40	38	18	54	15	6	5.5	6.6	11	6.5	M4	22	18	M6	0.6
BK17	17	35	9	44	7	86	64	43	39	50	55	28	68	19	8	6.6	9	14	8.5	M4	24	30	M6	1.3
BK20	20	35	8	43	8	88	60	44	34	52	50	22	70	19	8	6.6	9	14	8.5	M4	30	24	M6	1.3
BK25	25	42	12	54	9	106	80	53	48	64	70	33	85	22	10	9	11	17	11	M5	35	37	M6	2.4
BK30	30	45	14	61	9	128	89	64	51	76	78	33	102	23	11	11	14	20	13	M6	40	37	M6	3.4
BK35	35	50	14	67	12	140	96	70	52	88	79	35	114	26	12	11	14	20	13	M8	50	37	M6	4.4
BK40	40	61	18	76	15	160	110	80	60	100	90	37	130	33	14	14	18	26	17.5	M8	50	43	M6	6.8

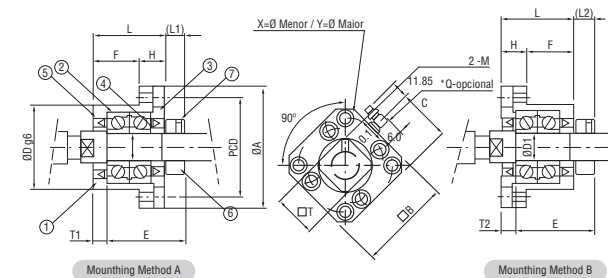

Modelo FK

Modelo	d1	L	H	F	E	Dg6	A	PCD	B	Montagem A		Montagem B		X	Y	Z	M	T	G	Q	Peso Kgs
										L1	T1	L2	T2								
FK12	12	27	10	17	29.5	36	54	44	44	7.5	5	8.5	6	4.5	8	4	M4	19	-	M6	0.26
FK15	15	32	15	17	36	40	63	50	52	10	6	12	8	5.5	9.5	6	M4	22	26	M6	0.4
FK17	17	45	22	23	47	50	77	62	61	11	9	14	12	6.6	11	10	M4	24	30.5	M6	0.85
FK20	20	52	22	30	50	57	85	70	68	8	10	12	14	6.6	11	10	M4	30	34	M6	1.2
FK25	25	57	27	30	59	63	98	80	79	13	10	20	17	9	15	13	M5	35	39.5	M6	1.6
FK30	30	62	30	32	61	75	117	95	93	11	12	17	18	11	17.5	15	M6	40	46.5	M6	2.38